

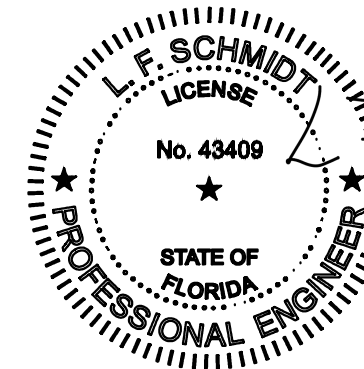

250 Staunton Turnpike, Parkersburg, WV 26104

5400, 5400S Series Vinyl Single Hung Window "NON-IMPACT"

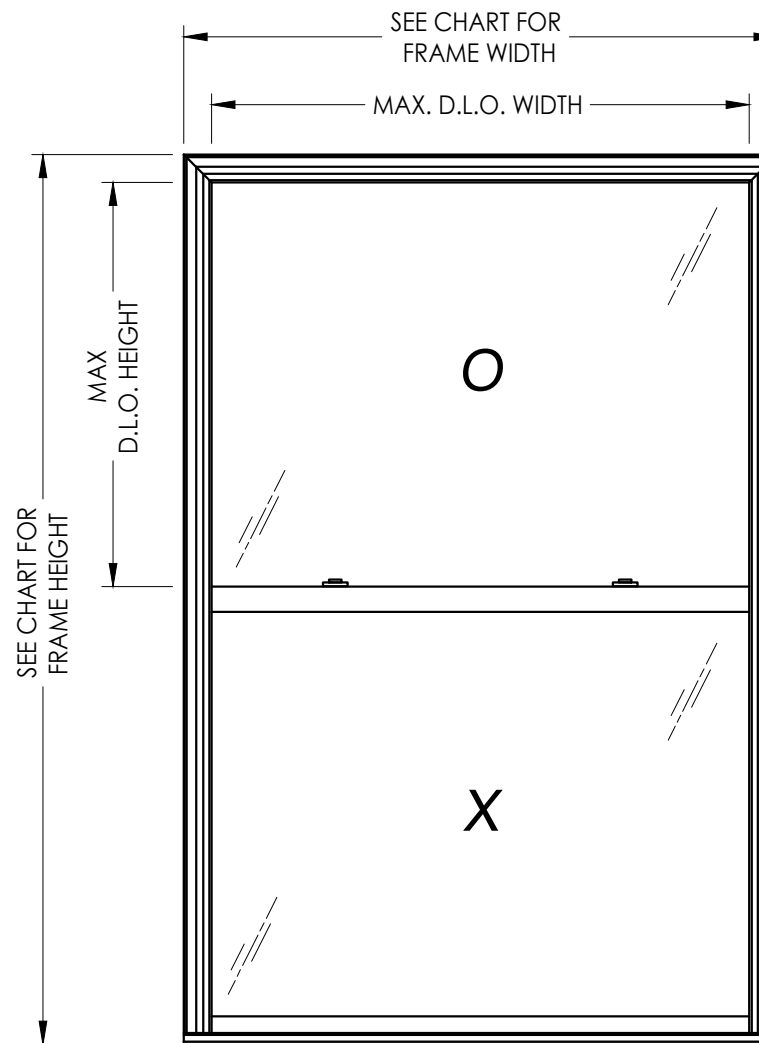

Lyndon F. Schmidt

This item has been digitally signed and sealed by L. F. Schmidt, P.E. on the date adjacent to the seal. Printed copies of this document are not considered signed and sealed and the signature must be verified on any electronic copies.

THIS PRODUCT APPROVAL IS VALID ONLY FOR THE STATE OF FLORIDA

GENERAL NOTES

- This product has been evaluated and is in compliance with the 8th Edition (2023) Florida Building Code (FBC) structural requirements excluding the "High Velocity Hurricane Zone" (HVHZ).
- Product anchors shall be as listed and spaced as shown on details. Anchor embedment to base material shall be beyond wall dressing or stucco.
- When used in areas requiring wind borne debris protection this product is required to be protected with an impact resistant covering that complies with FBC Sections 1609.1.2 & R301.2.1.2.
- For 2x stud framing construction, anchoring of these units shall be the same as that shown for 2x buck masonry construction.
- Site conditions that deviate from the details of this drawing require further engineering analysis by a licensed engineer or registered architect.

TABLE OF CONTENTS	
SHEET#	DESCRIPTION
1	Typical elevations, design pressures and general notes
2	Horizontal cross sections
3	Vertical cross sections
4	Buck and frame anchoring
5	Bill of materials, components & glazing details

MAX. FRAME DIMENSION	MAX. D.L.O. DIMENSION	GLASS TYPE	DESIGN PRESSURE (PSF)	
			POSITIVE	NEGATIVE
40.0" X 42.0"	35.5" X 17.75"	G1	+50.0	-60.0
36.0" X 48.0"	31.5" X 20.75"	G1	+50.0	-60.0
32.0" X 54.0"	27.5" X 23.75"	G1	+50.0	-60.0
48.0" X 40.0"	43.5" X 16.75"	G1	+45.0	-55.0
44.0" X 42.0"	39.5" X 17.75"	G1	+45.0	-55.0
40.0" X 48.0"	35.5" X 20.75"	G1	+45.0	-55.0
36.0" X 52.0"	31.5" X 22.75"	G1	+45.0	-55.0
32.0" X 60.0"	27.5" X 26.75"	G1	+45.0	-55.0
48.0" X 44.0"	43.5" X 18.75"	G1	+40.0	-50.0
44.0" X 48.0"	39.5" X 20.75"	G1	+40.0	-50.0
40.0" X 54.0"	35.5" X 23.75"	G1	+40.0	-50.0

MAX. FRAME DIMENSION	MAX. D.L.O. DIMENSION	GLASS TYPE	DESIGN PRESSURE (PSF)	
			POSITIVE	NEGATIVE
36.0" X 60.0"	31.5" X 26.75"	G1	+40.0	-50.0
32.0" X 66.0"	27.5" X 29.75"	G1	+40.0	-50.0
48.0" X 50.0"	43.5" X 21.75"	G1	+35.0	-45.0
44.0" X 56.0"	39.5" X 24.75"	G1	+35.0	-45.0
40.0" X 60.0"	35.5" X 26.75"	G1	+35.0	-45.0
36.0" X 68.0"	31.5" X 30.75"	G1	+35.0	-45.0
32.0" X 72.0"	27.5" X 32.75"	G1	+35.0	-45.0
48.0" X 60.0"	43.5" X 26.75"	G1	+30.0	-40.0
44.0" X 64.0"	39.5" X 28.75"	G1	+30.0	-40.0
40.0" X 72.0"	35.5" X 32.75"	G1	+30.0	-40.0
48.0" X 72.0"	43.5" X 32.75"	G1	+25.0	-35.0

Documents Prepared By:
Lyndon F. Schmidt
P.E. No. 43409

RW
BUILDING CONSULTANTS, INC.
P.O. Box 230, Vairico, FL 33595
Phone No.: 813.659.9197
FBPE Registry No. 9813

PRODUCT: 5400, 5400S SERIES Vinyl Single Hung Window
PART OR ASSEMBLY: TYPICAL ELEVATION, DESIGN PRESSURES & GENERAL NOTES

NO.	DATE	REVISIONS
5	7/06/23	UPDATE TO 8TH ED. (2023) FBC
4	7/02/20	UPDATE TO 7TH ED. (2020) FBC
3	6/01/17	UPDATE TO 6TH ED. (2017) FBC
2	6/09/16	REVISE INSTALLATION SCREWS
1	2/12/15	UPDATE TO 5TH ED. (2014) FBC

DATE: 6/22/14
SCALE: N.T.S.
DWG. BY: JK
CHK. BY: LFS
DRAWING NO.: FL-17088.1
SHEET 1 OF 5

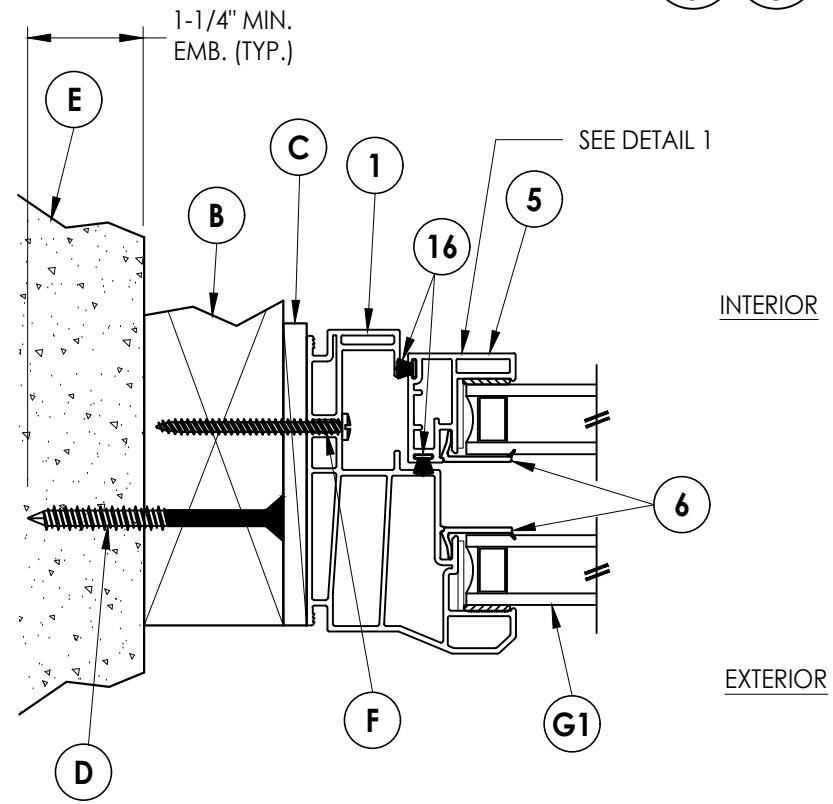
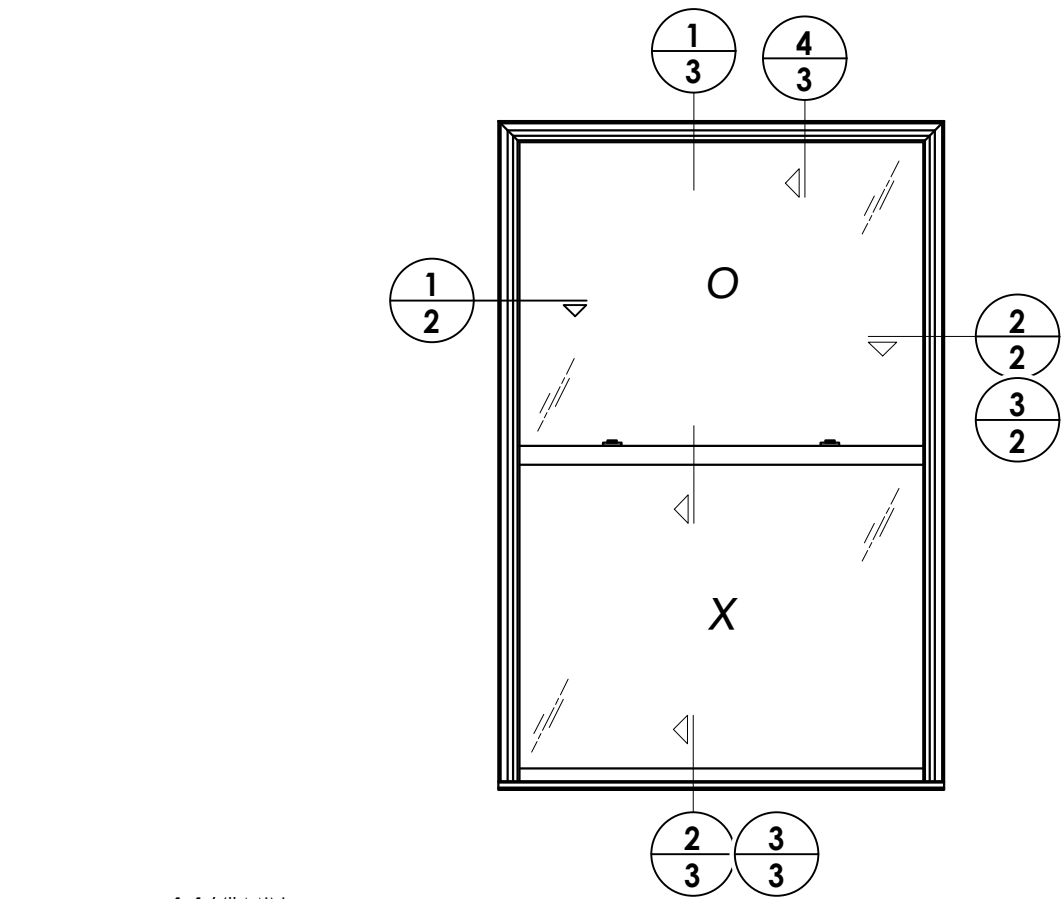

1 HORIZONTAL CROSS SECTION
2 Shown w/ 2X buck

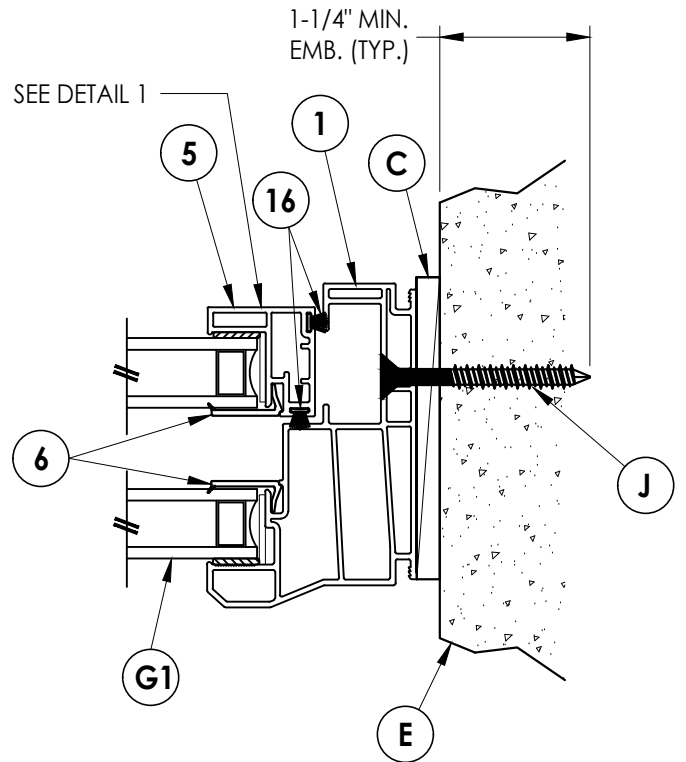

2 HORIZONTAL CROSS SECTION
2 Shown direct to masonry

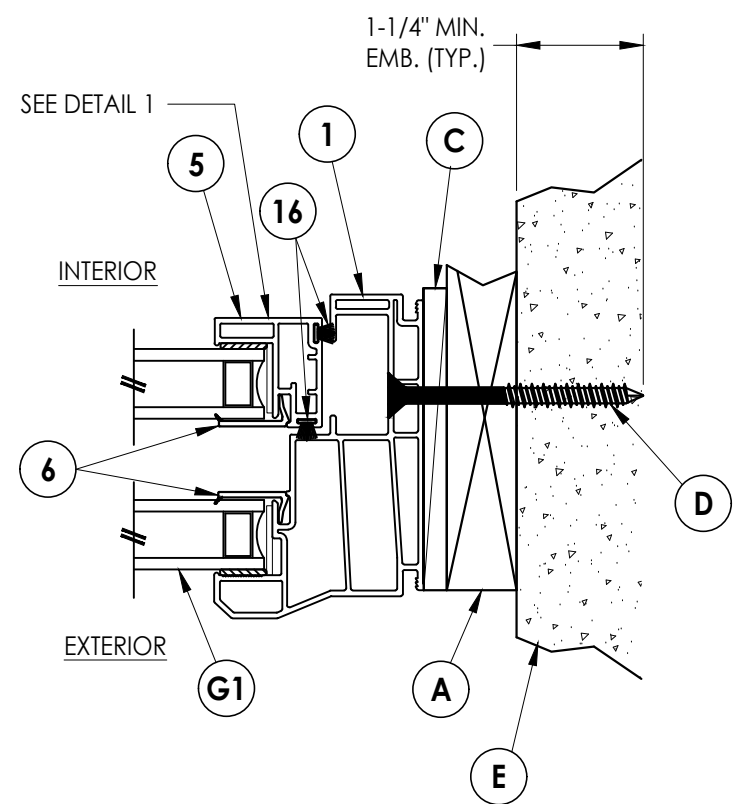

3 HORIZONTAL CROSS SECTION
2 Shown w/ 1X buck

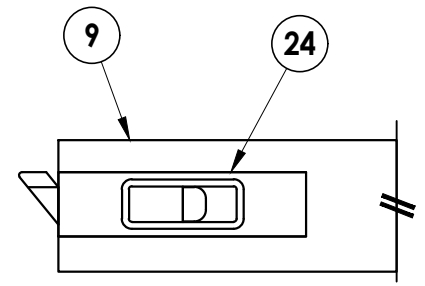

DETAIL 1

Documents Prepared By: Lyndon F. Schmidt P.E. No. 43409		 BUILDING CONSULTANTS, INC. P.O. Box 230, Valrico, FL 33595 Phone No.: 813.659.9197 FBPE Registry No. 9813	
PRODUCT: 5400, 5400S SERIES Vinyl Single Hung Window		PART OR ASSEMBLY: HORIZONTAL CROSS SECTIONS	
5	7/06/23	UPDATE TO 8TH ED. (2023)	FBC
4	7/02/20	UPDATE TO 7TH ED. (2020)	FBC
3	6/01/17	UPDATE TO 6TH ED. (2017)	JK
2	6/09/16	REVISE INSTALLATION SCREWS	LFS
1	2/12/15	UPDATE TO 5TH ED. (2014)	FBC
NO.	DATE	REVISIONS	
DATE: 6/22/14			
SCALE: N.T.S.			
DWG. BY: JK			
CHK. BY: LFS			
DRAWING NO.: FL-17088.1			
SHEET 2 of 5			

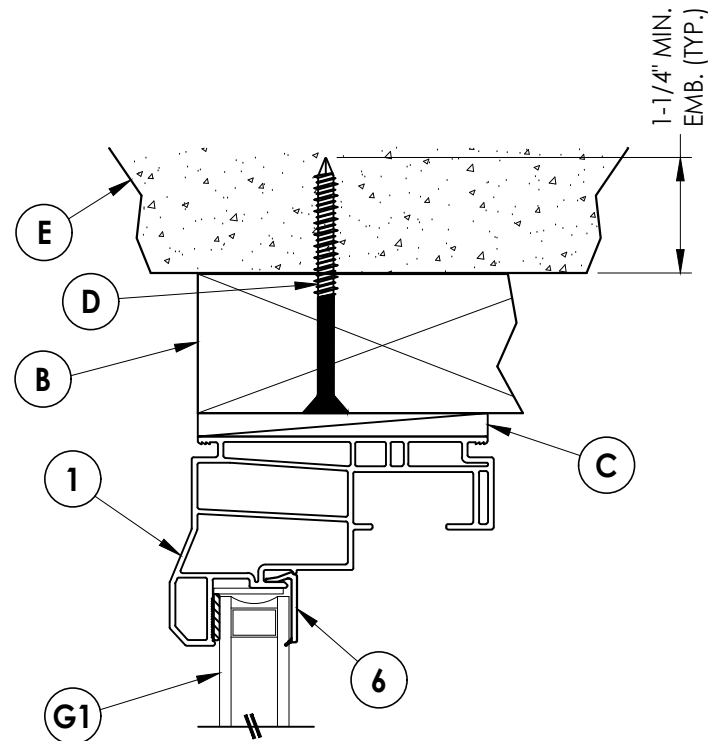

1 VERTICAL CROSS SECTION
3 Shown w/ 2X buck

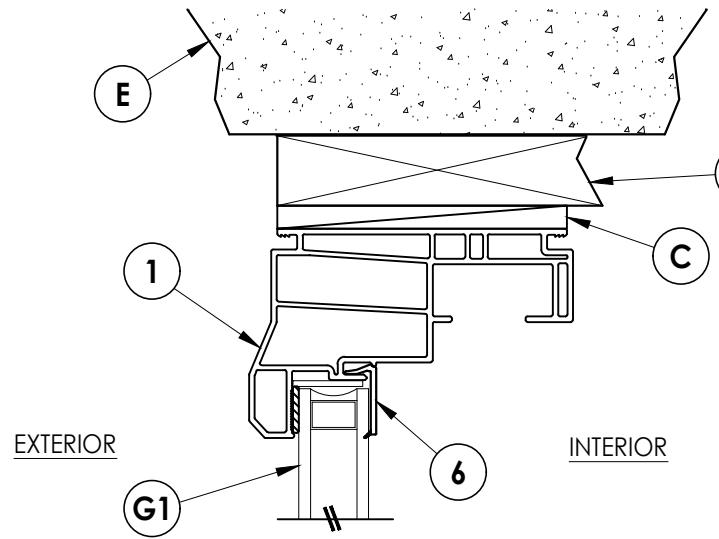
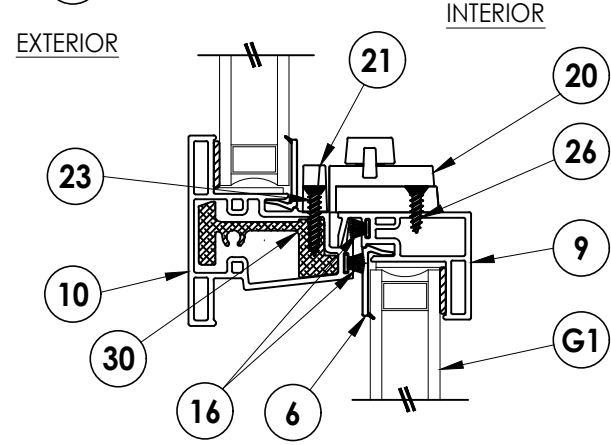

4 VERTICAL CROSS SECTION
3 Shown w/ 1X buck

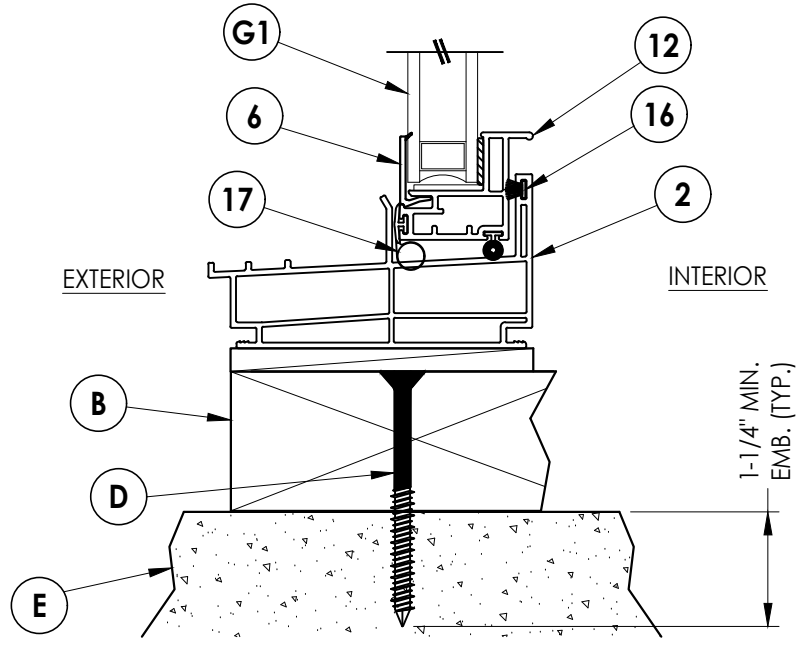

2 VERTICAL CROSS SECTION
3 Shown w/ 2X buck

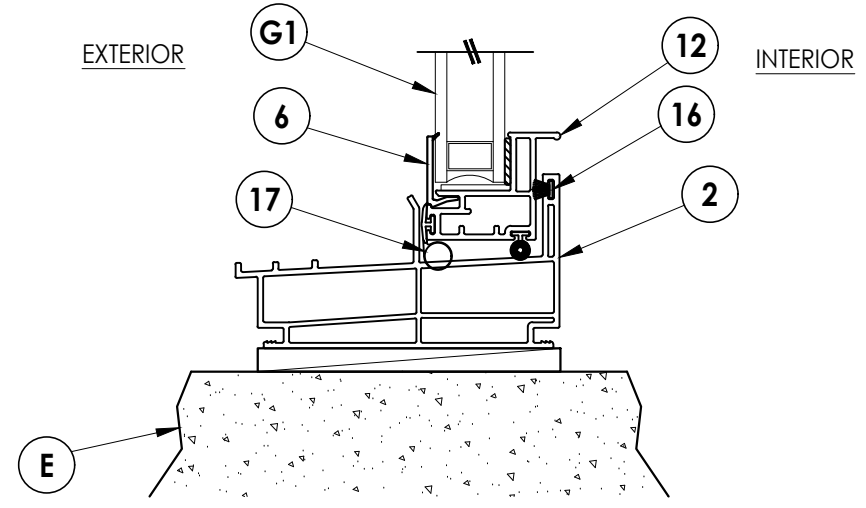

3 VERTICAL CROSS SECTION
3 Shown direct to masonry

Documents Prepared By:
 Lyndon F. Schmidt
 P.E. No. 43409

RW BUILDING CONSULTANTS, INC.
 P.O. Box 230, Valrico, FL 33595
 Phone No.: 813.659.9197
 FBPE Registry No. 9813

PRODUCT:
 5400, 5400S SERIES
 Vinyl Single Hung Window

PART OR ASSEMBLY:
 VERTICAL
 CROSS SECTIONS

NO.	DATE	REVISIONS
5	7/06/23	UPDATE TO 8TH ED. (2023) FBC LFS
4	7/02/20	UPDATE TO 7TH ED. (2020) FBC LFS
3	6/01/17	UPDATE TO 6TH ED. (2017) FBC JK
2	6/09/16	REVISE INSTALLATION SCREWS LFS
1	2/12/15	UPDATE TO 5TH ED. (2014) FBC JK

DATE: 6/22/14
 SCALE: N.T.S.
 DWG. BY: JK
 CHK. BY: LFS
 DRAWING NO.:
 FL-17088.1
 SHEET 3 OF 5

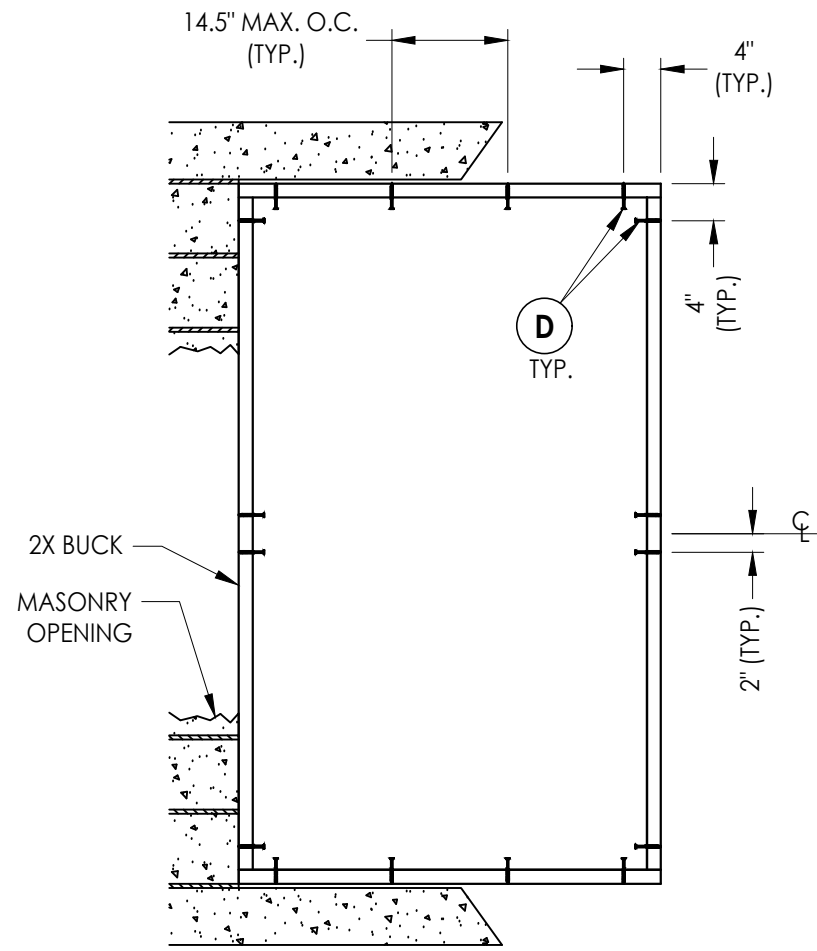

BUCK ANCHORING

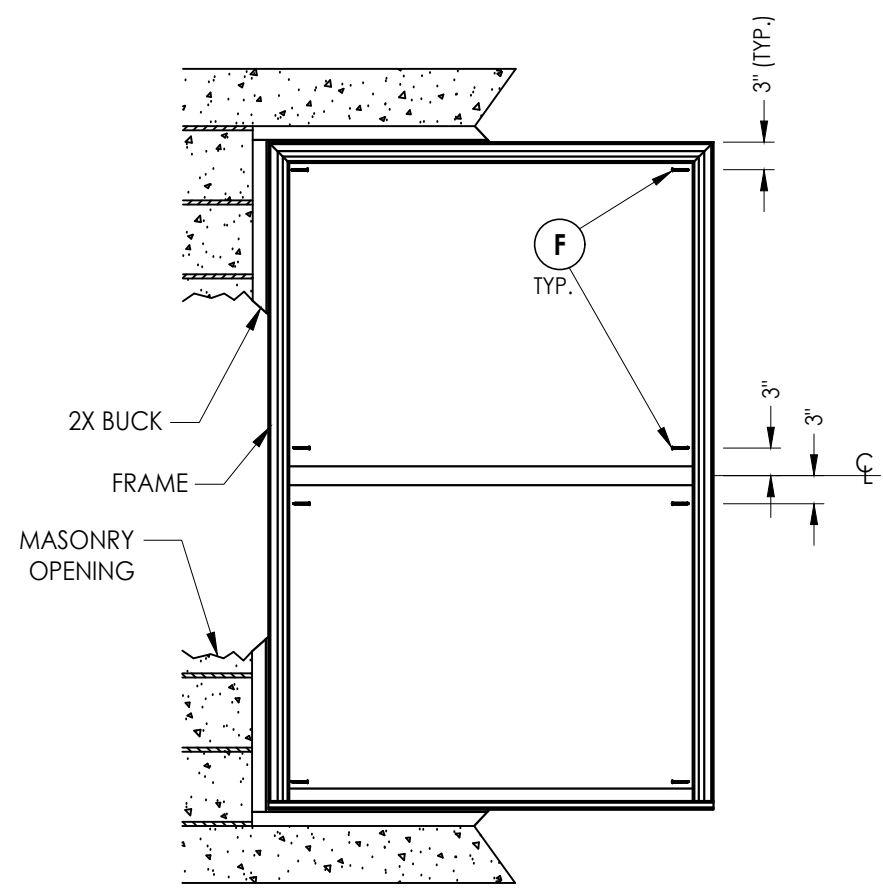

FRAME ANCHORING
2X Buck

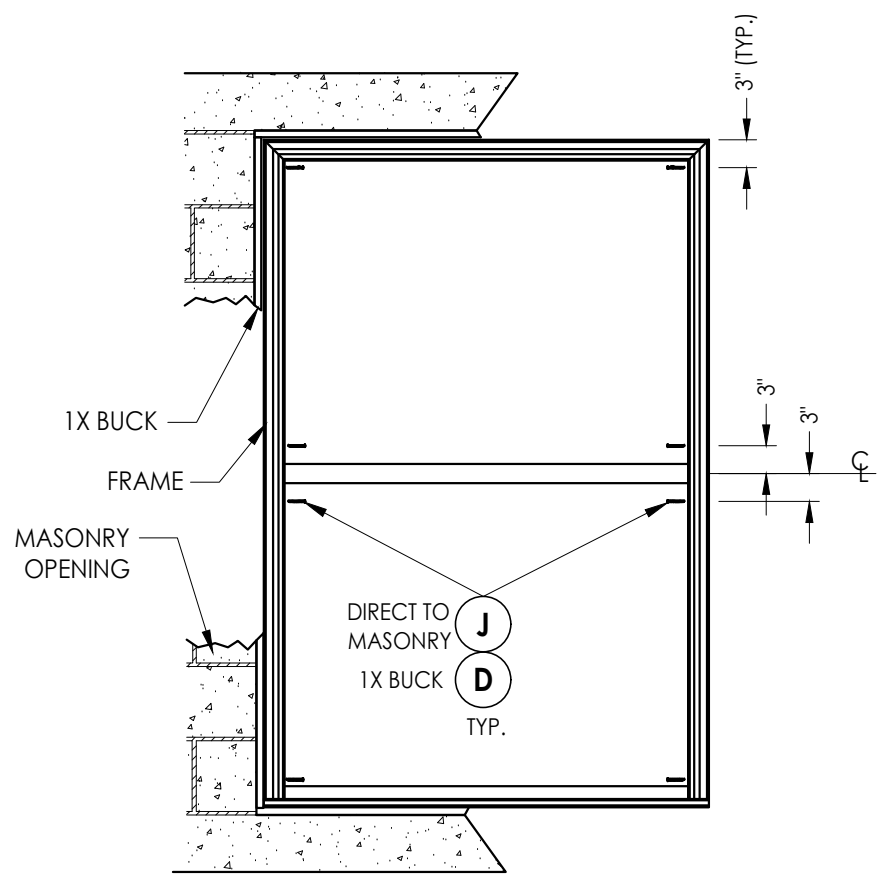

FRAME ANCHORING
1X Buck
Direct to masonry

CONCRETE ANCHOR NOTES:

1. Concrete anchor locations at the corners may be adjusted to maintain the min. edge distance to mortar joints.
2. Concrete anchor locations noted as "MAX. ON CENTER" must be adjusted to maintain the min. edge distance to mortar joints, additional concrete anchors may be required to ensure the "MAX. ON CENTER" dimension are not exceeded.
3. Concrete anchor table:

ANCHOR TYPE	ANCHOR SIZE	MIN. EMBEDMENT	MIN. CLEARANCE TO MASONRY EDGE	MIN. CLEARANCE TO ADJACENT ANCHOR
ITW TAPCON®	1/4"	1-1/4"	2"	4"
DeWALT ULTRACON®	1/4"	1-1/4"	1"	4"

WOOD SCREW INSTALLATION NOTES:

1. Maintain a minimum 5/8" edge distance, 1" end distance, & 1" o.c. spacing of wood screws to prevent the splitting of wood.

Documents Prepared By:
Lyndon F. Schmidt
P.E. No. 43409



BUILDING CONSULTANTS, INC.
P.O. Box 230, Valrico, FL 33595
Phone No.: 813.659.9197
FBPE Registry No. 9813

PRODUCT:
5400, 5400S SERIES
Vinyl Single Hung Window

PART OR ASSEMBLY:
BUCK AND
FRAME ANCHORING

NO.	DATE	REVISIONS
5	7/06/23	UPDATE TO 8TH ED. (2023) FBC
4	7/02/20	UPDATE TO 7TH ED. (2020) FBC
3	6/01/17	UPDATE TO 6TH ED. (2017) FBC
2	6/09/16	REVISE INSTALLATION SCREWS
1	2/12/15	UPDATE TO 5TH ED. (2014) FBC

DATE: 6/22/14
SCALE: N.T.S.
DWG. BY: JK
CHK. BY: LFS
DRAWING NO.: FL-17088.1
SHEET 4 OF 5

BILL OF MATERIALS

ITEM #	DESCRIPTION	MATERIAL
A	1X BUCK SG >= 0.42	WOOD
B	2X BUCK SG >= 0.42	WOOD
C	1/4" MAX. SHIM SPACE	-
D	1/4" X 2-3/4" PFH DeWALT OR ITW CONCRETE SCREW	STEEL
E	MASONRY - 3,000 PSI MIN. CONCRETE CONFORMING TO ACI 301 OR HOLLOW BLOCK CONFORMING TO ASTM C90	CONCRETE
F	#8 X 2" PAN HEAD/TRUSS HEAD WOOD SCREW (1-3/8" MIN. EMBEDMENT)	STEEL
J	1/4" X 2-1/4" PFH DeWALT OR ITW CONCRETE SCREW	STEEL
1	FRAME HEAD AND JAMB*	PVC
2	SILL*	PVC
5	SASH STILE*	PVC
6	GLAZING BEAD*	PVC
9	LOCK RAIL LOWER SASH*	PVC
10	STAYBAR*	PVC
12	BOTTOM RAIL LOWER SASH*	PVC
16	WEATHERSTRIP ULTRA FAB .270 PILE - 270 -1875B	-
17	WEATHERSTRIP SILLBULB (AMESBURY 32690)	-
20	LOCK 8513 / 8845 LAWRENCE	PVC
21	KEEPER 2700 - 214 LAWRENCE	PVC
23	#6 X 3/4" PFH (VINYL LOCK SCREWS)	STEEL
24	SASH TILT LATCH - ASHLAND	PVC
26	#6 X 1/2" PFH (VINYL LOCK SCREWS)	STEEL
30	REINFORCEMENT (FIXED MEETING RAIL) ALUM. 6063-T6	ALUM

* THE APPROVED WHITE RIGID PVC EXTERIOR EXTRUSIONS FOR WINDOWS ARE TO BE PRODUCED BY EXTRUDERS LICENSEES IN "AAMA CERTIFICATION PROGRAMS FOR RIGID PVC EXTRUSIONS".

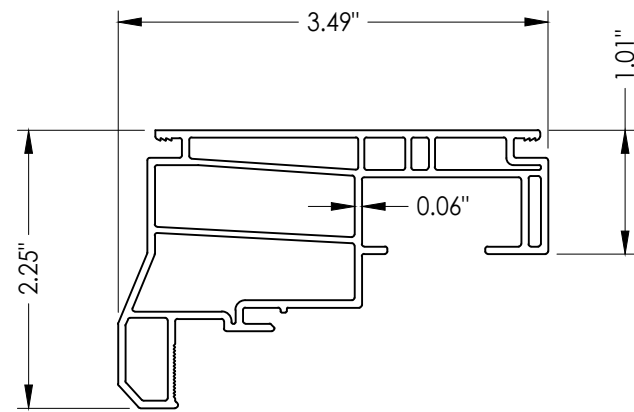

1 FRAME HEAD & JAMB

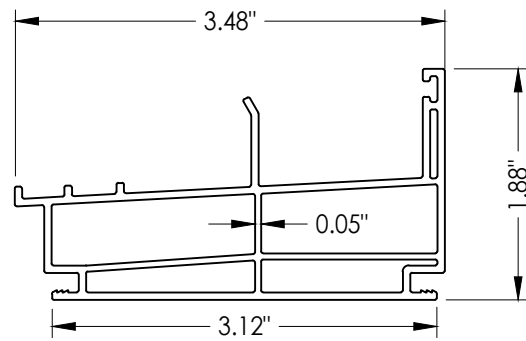

2 SILL

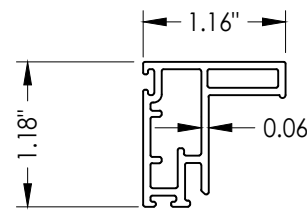

5 SASH STILE

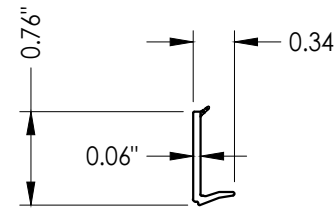

6 GLAZING BEAD

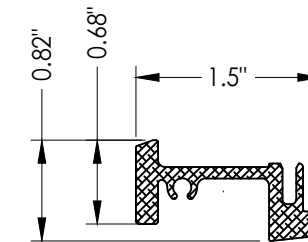

30 REINFORCEMENT
FIXED MEETING RAIL

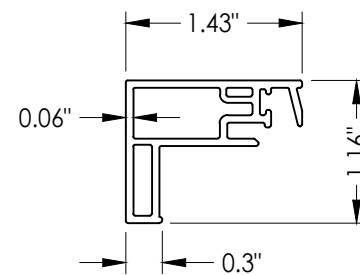

9 LOCK RAIL
Lower Sash

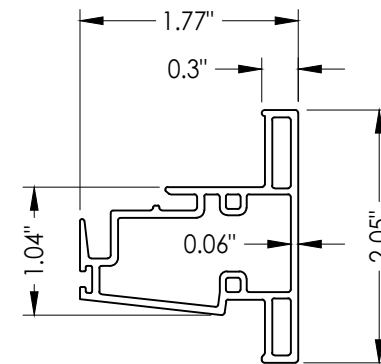

10 STAYBAR

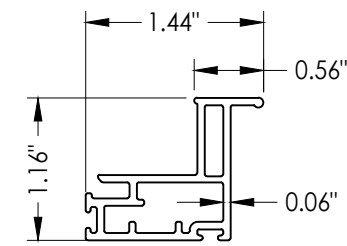

12 BOTTOM RAIL
Lower Sash

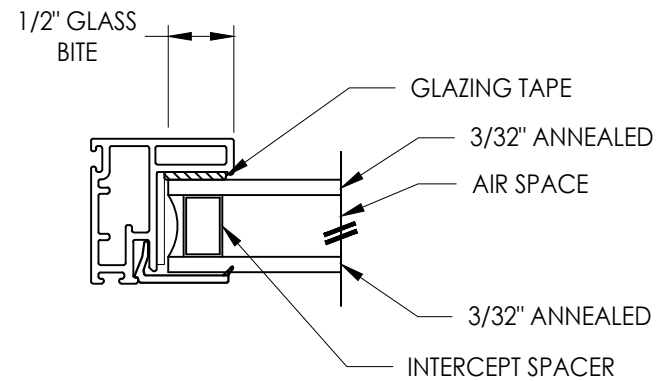

G1 GLAZING DETAIL

Documents Prepared By:
Lyndon F. Schmidt
P.E. No. 43409

RW BUILDING CONSULTANTS, INC.
P.O. Box 230, Vairico, FL 33595
Phone No.: 813.659.9197
FBPE Registry No. 9813

PRODUCT: 5400, 5400S SERIES
Vinyl Single Hung Window
PART OR ASSEMBLY:
BILL OF MATERIALS
COMPONENTS & GLAZING DETAILS

NO.	DATE	REVISIONS
5	7/06/23	UPDATE TO 8TH ED. (2023) FBC LFS
4	7/02/20	UPDATE TO 7TH ED. (2020) FBC LFS
3	6/01/17	UPDATE TO 6TH ED. (2017) FBC LFS
2	6/09/16	REVISE INSTALLATION SCREWS LFS
1	2/12/15	UPDATE TO 5TH ED. (2014) FBC JK
		BY

DATE: 6/22/14
SCALE: N.T.S.
DWG. BY: JK
CHK. BY: LFS
DRAWING NO.: FL-17088.1
SHEET 5 OF 5